

Industrial Grade AC/DC Power Supply With PFC

85-264Vrms Input Voltage	12/15/24/28/48V Semi-Regulated Output	1400W Output Continuous	1800W Output Transient	92% Full Load Efficiency
------------------------------------	---	-----------------------------------	----------------------------------	------------------------------------



Product Features

- High efficiency (92% for 48 VOUT Model at 1400W)
- Universal input voltage range
- Semi-regulated output for bus stability
- Integral fan cooling with speed control
- Active PFC; EN61000-3-2 compliant
- Low noise; EN55011 / EN55022 Class B compliant
- Over-current, over-voltage, & over-temp protection
- DC Power Good / AC Power Good signals
- Fan status output / Remote enable input
- Small size: 4.75" x 7" x 1.625" (encased)
- RoHS 6/6 compliant
- 5 V (500 mW) standby output
- Parallel option (24 V, 28 V, 48 V only)

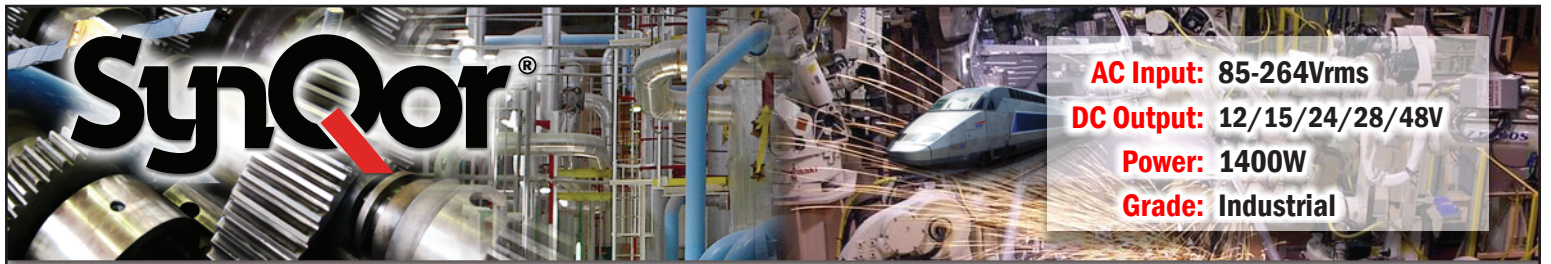

AC Input: 85-264Vrms
DC Output: 12/15/24/28/48V
Power: 1400W
Grade: Industrial

ACuQor 1400W Series Electrical Characteristics

All specifications typical with TA = 25 °C, unless otherwise specified. Specifications subject to change without notice.

MAIN OUTPUT SPECIFICATIONS			GENERAL SPECIFICATIONS		
Output power (continuous) (5 s transient)	85-132/170-264 Vrms	1400W	Fundamental ripple freq.	Input	500 kHz
	85-132/170-264 Vrms	1800W		Output	250 kHz
Nominal DC output voltage (at 800W) (Semi-regulated)	132-170 Vrms	See Figure 12	Audible noise Weight	Fan speed varies with temp.	45 dBA @ 1 m max.
	12 Vout	12.4 V		(AQ0800xxxxGC)	998 g (35.2 oz)
	15 Vout	15.6 V		(AQ1100xxxxGC)	1179 g (41.6 oz)
	24 Vout	25 V		(AQ1400xxxxGC)	1179 g (41.6 oz)
	28 Vout	29 V	MTBF	MIL-217	533 kHours
Efficiency (see figs. 1 - 10)	48 Vout	50 V	ISOLATION SPECIFICATIONS		
	12 Vout, 115 Vrms, 1400W	87% typ.	Isolation voltage	Input to output	3000 Vrms
	24 Vout, 115 Vrms, 1400W	89% typ.		Input to ground	1768 Vrms
	48 Vout, 115 Vrms, 1400W	90% typ.	Output to ground	500 Vrms	
	12 Vout, 230 Vrms, 1400W	89.5% typ.	Insulation resistance	Output to ground	10 MΩ min.
24 Vout, 230 Vrms, 1400W	90.5% typ.	Leakage currents		See Note 2	
Hold-up time (to -20%)	48 Vout, 230 Vrms, 1400W	91.5% typ.	ENVIRONMENTAL CHARACTERISTICS		
	12 / 15 Vout	10 ms @ 1400W	Thermal performance	Operating ambient (see Fig 11)	-40 °C to +70 °C
24 / 28 / 48 Vout	12 ms @ 1400W	Non-operating ambient		-40 °C to +85 °C	
Maximum load capacitance	12 Vout	48,000 μF	Relative humidity	Non-condensing	5-95% RH
	15 Vout	40,500 μF	Altitude	Operating	10,000 ft max.
	24 Vout	24,000 μF		Non-operating	30,000 ft max.
	28 Vout	19,200 μF	Random vibration Shock	5-500 Hz	0.03 g2/Hz
	48 Vout	6,000 μF		Half-sine, 10 ms, 3 axes	20 g peak
Output ripple voltage	Switching frequency (20 MHz BW)	0.5% p-p	EMC CHARACTERISTICS		
	Twice line frequency (at 800W)	5.0% p-p	Conducted emissions	EN55011 and EN5022, FCC	Level B
Turn-on delay		2.5 s max.	Line frequency harmonics	EN61000-3-2	Class A
Transient response	Iout steps from 50-75%	3% typ / 6% max. dev.	Voltage fluctuations	EN61000-3-3	Clause 5b
	At 0.2 A/μs	100 ms recovery	ESD air	EN61000-4-2	Level 3
Overvoltage protection	Cyclic restart	110-120%	ESD contact	EN61000-4-2	Level 3
Short circuit protection	Cyclic operation	115% rated Iout	Radiated immunity	EN61000-4-3	Level 3
Total regulation	Over line, load and temperature	±6.0%	Fast transients	EN61000-4-4	Level 3
Auxiliary Output	Always on (See Note 1)	5 V @ 100 mA	Line surge immunity	EN61000-4-5	Level 3
Thermal protection	Automatic recovery	+125 °C (PCB Temp)	Conducted immunity	EN61000-4-6	Level 3
REMOTE_ENABLE	Input Low Voltage	0.45 V (max)	Power freq. mag. field	EN61000-4-8	3 A/m
	Input High Voltage	4.15 V (min)	Voltage dip immunity	EN61000-4-11	Perf Criteria B, A, B <5% UT 10 ms, 70% UT 500 ms, 40% UT 100 ms
INPUT SPECIFICATIONS					
AC input voltage	Universal range	85-264 Vrms			
Input frequency		47-63 Hz			
Input current	115 Vrms @ 1400W	14 Arms			
	230 Vrms @ 1400W	7 Arms			
Power factor		>0.98			
Input surge current	264 Vrms (cold start)	50 A max.			
Internal input fuses	Both AC lines	20 A			

- NOTES:
 1. Derate 2 mA per °C above 50 °C ambient temperature.
 2. See Leakage Currents Table.

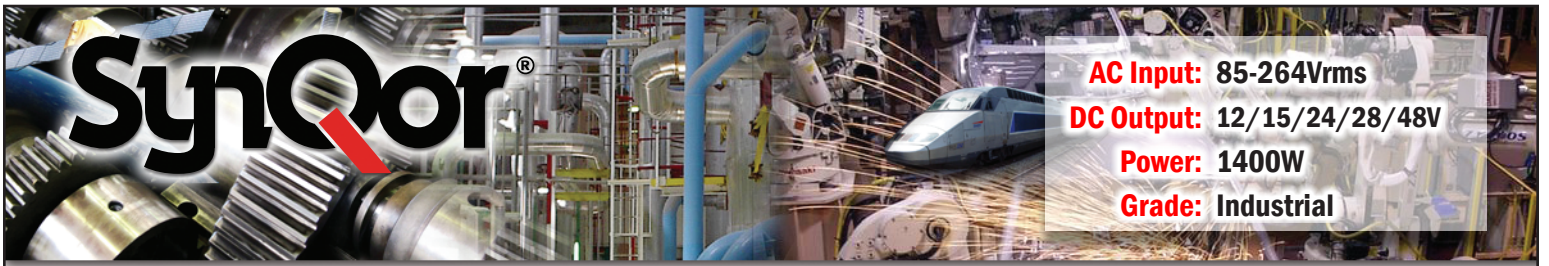

EFFICIENCY, DERATING, AND V_{OUT} DROOP CURVES

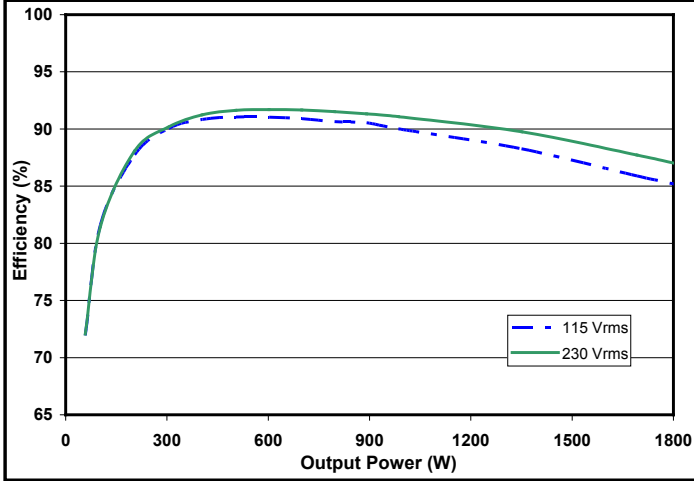

Figure 1: 12 VOUT efficiency curves.

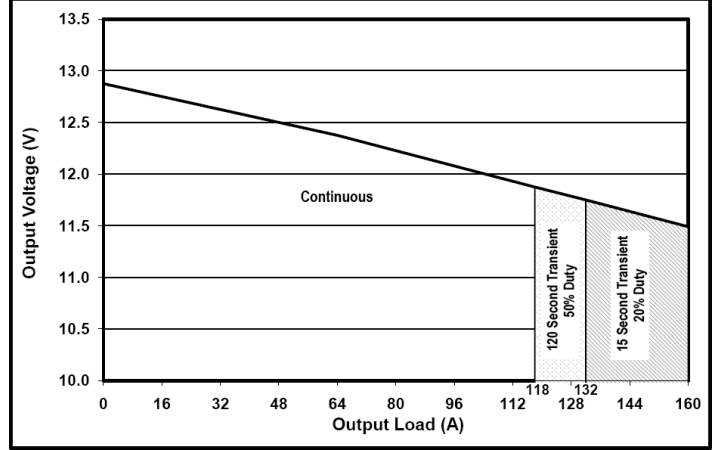

Figure 2: 12 VOUT droop characteristic.

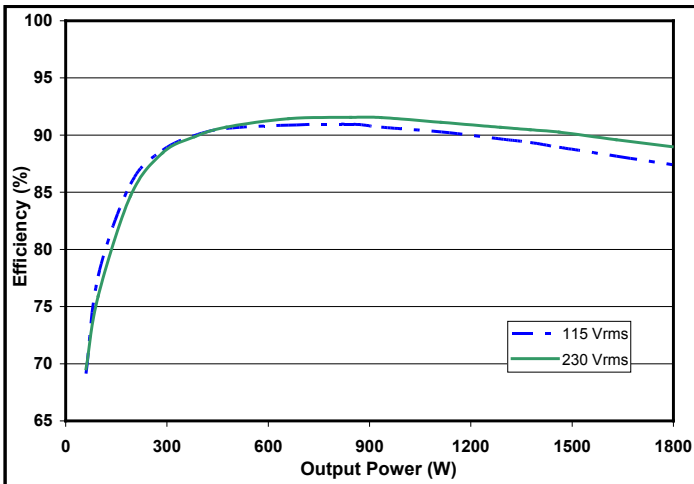

Figure 3: 15 VOUT efficiency curves.

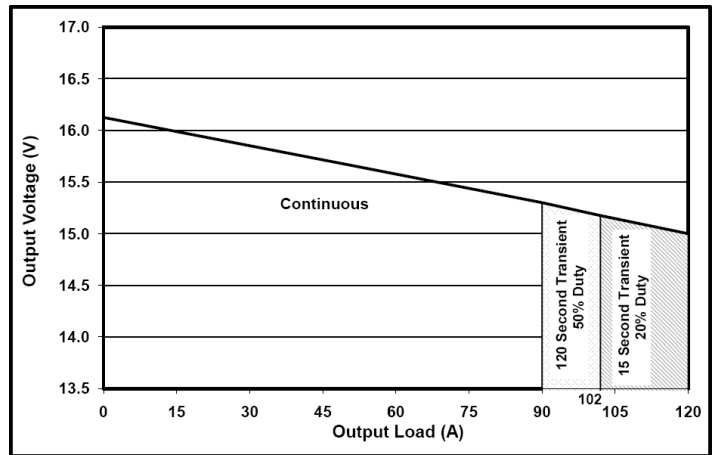

Figure 4: 15 VOUT droop characteristic.

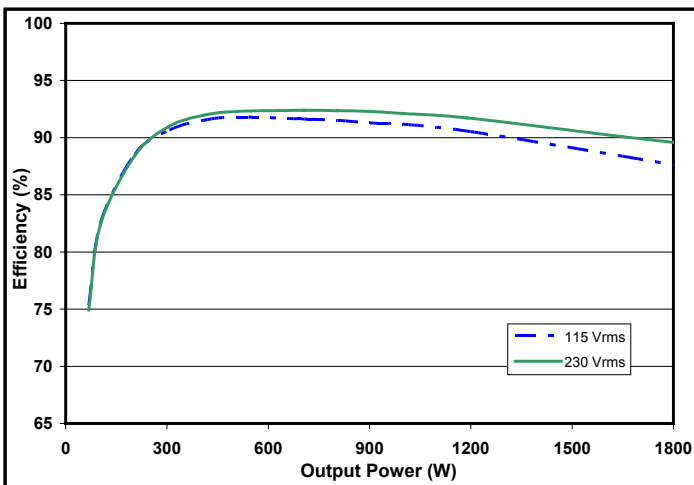

Figure 5: 24 VOUT efficiency curves.

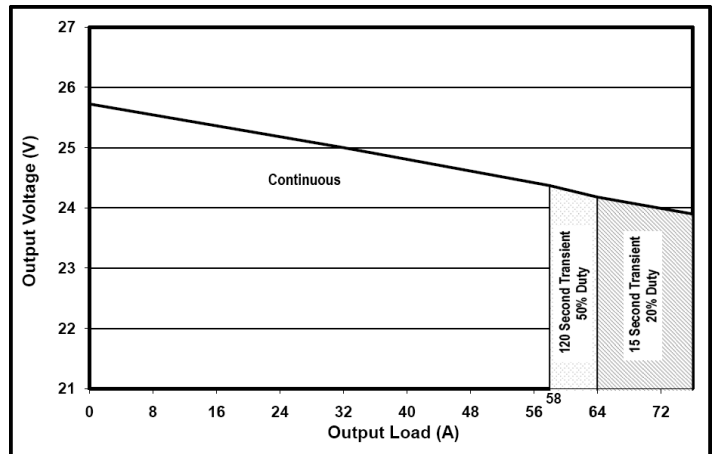

Figure 6: 24 VOUT droop characteristic.

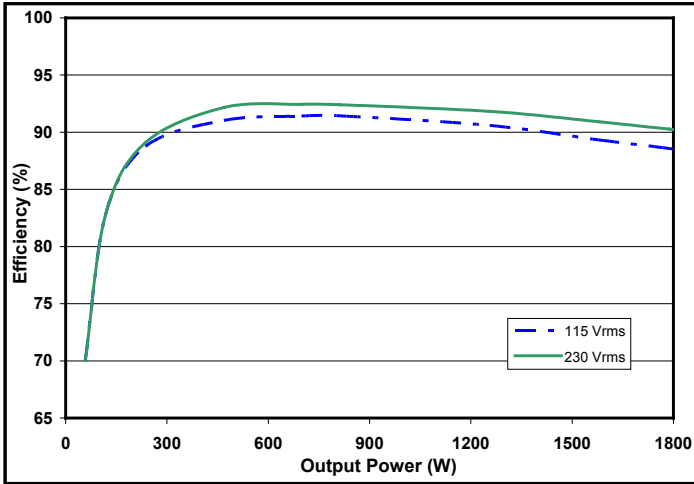
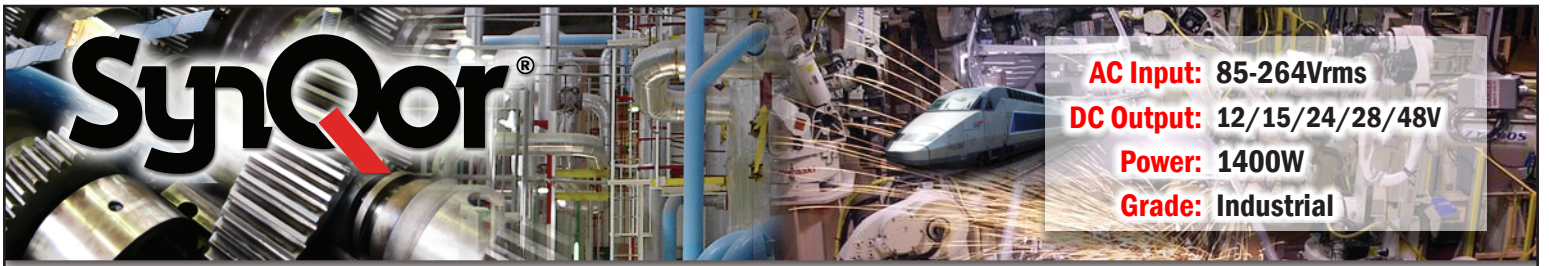

Figure 7: 28 VOUT efficiency curves.

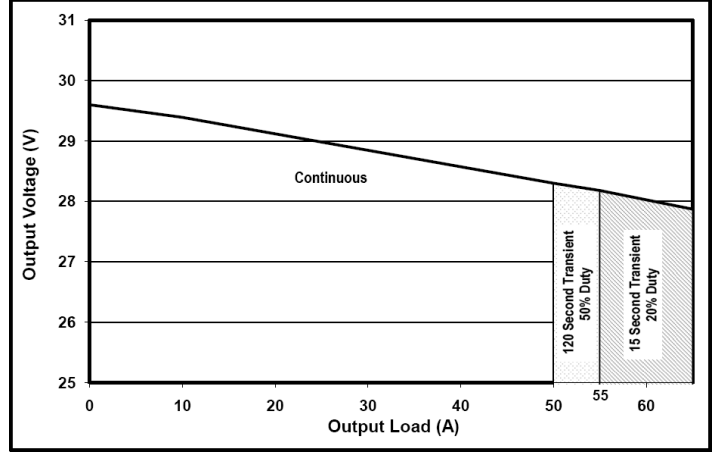

Figure 8: 28 VOUT droop characteristics.

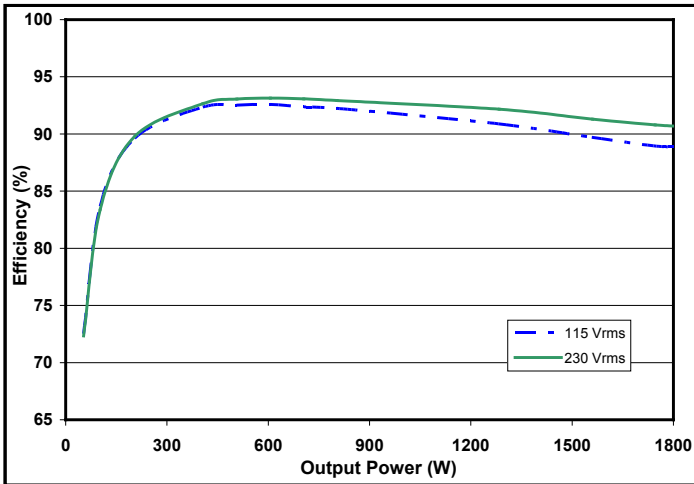

Figure 9: 48 VOUT efficiency curves.

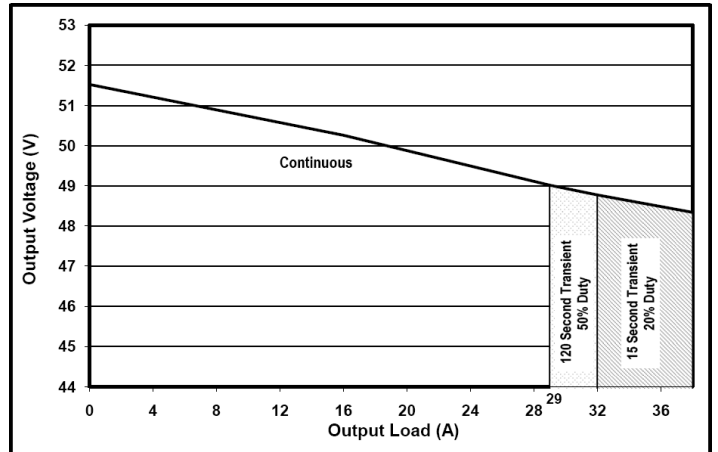

Figure 10: 48 VOUT droop characteristics.

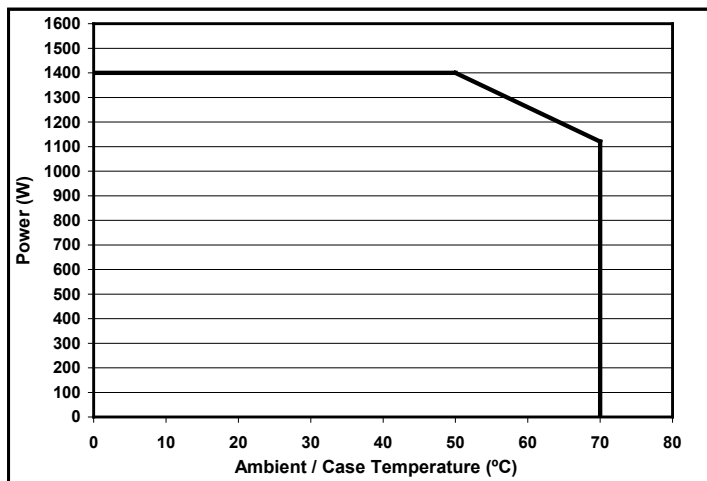

Figure 11: Continuous power derating curve in natural convection.

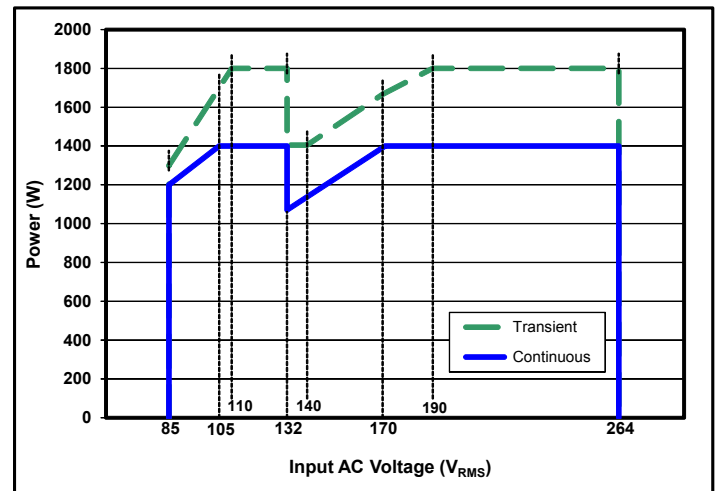
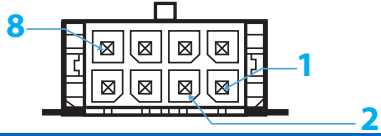
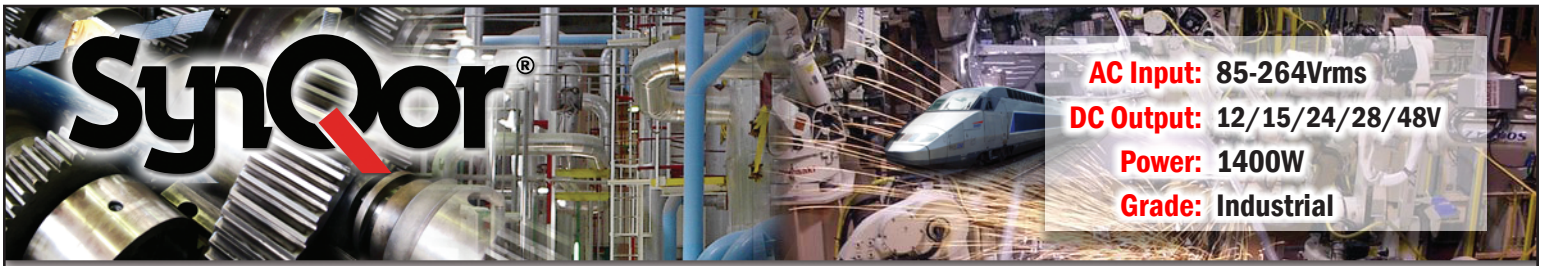

Figure 12: Rated output power vs Input AC Voltage.



OUTPUT DATA CONNECTOR PINOUT

Pin 1	Reserved	Reserved for future use.
Pin 2	Reserved	Reserved for future use.
Pin 3	VOUT(-)	Negative Output Voltage
Pin 4	REMOTE_ENABLE	Logic input. See Figure B. Pull high to enable main output.
Pin 5	FAN_GOOD	Open collector with internal 5 V pullup. See Figure A. Pulsed low on fan failure, 100 ms, 50% duty.
Pin 6	AC_POWER_GOOD	Open collector with internal 5 V pullup. See Figure A. Pulled low on AC power dropout.
Pin 7	DC_POWER_GOOD	Open collector with internal 5 V pullup. See Figure A. Pulled low during startup ramp and within 5°C of temperature shutdown threshold.
Pin 8	5V_STANDBY	5 V @ 100 mA available whenever AC power is applied.

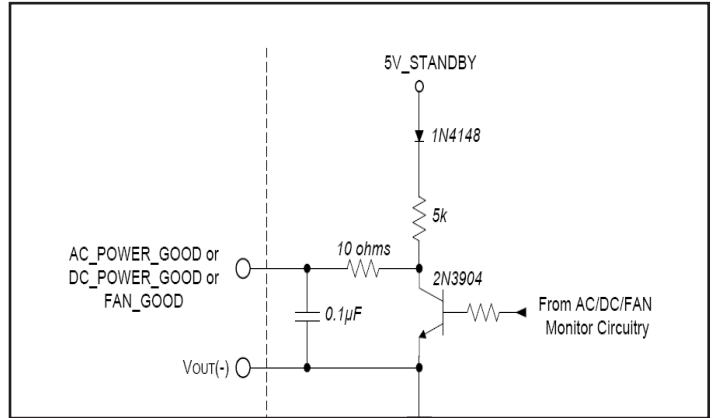
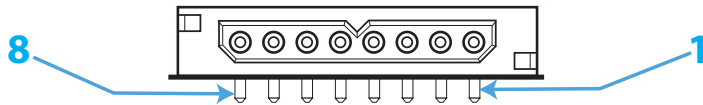

Figure A: Power good and fan good interface circuitry.



OUTPUT POWER CONNECTOR PINOUT

Pin 1	VOUT(+)	Positive Output Voltage
Pin 2	VOUT(-)	Negative Output Voltage
Pin 3	VOUT(+)	Positive Output Voltage
Pin 4	VOUT(-)	Negative Output Voltage
Pin 5	VOUT(+)	Positive Output Voltage
Pin 6	VOUT(-)	Negative Output Voltage
Pin 7	VOUT(+)	Positive Output Voltage
Pin 8	VOUT(-)	Negative Output Voltage

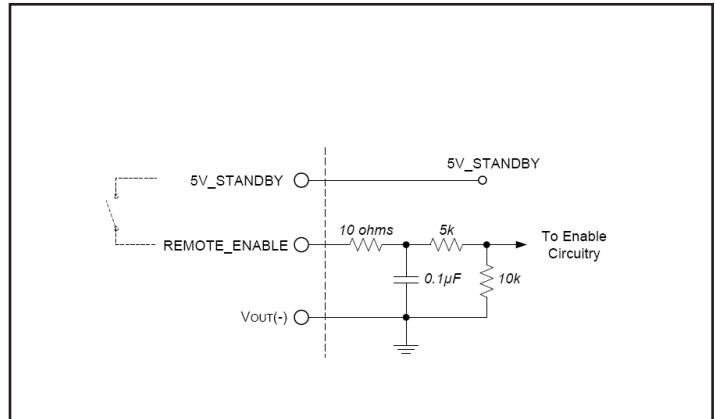
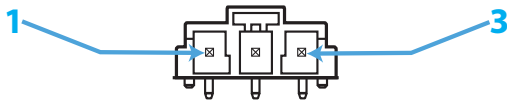

Figure B: Remote enable interface circuitry.



INPUT CONNECTOR PINOUT

Pin 1	Ground
Pin 2	AC Neutral
Pin 3	AC Line

MATING CONNECTORS

Connector	Type	Contact
OUTPUT (Power)	Positronic PLA08M7	Positronic MS112N
OUTPUT (Data)	Molex 43025-0800	Molex 43030-0008
INPUT	Hirose DF22B-3S-7.92C	Hirose DF22A-1012SCA

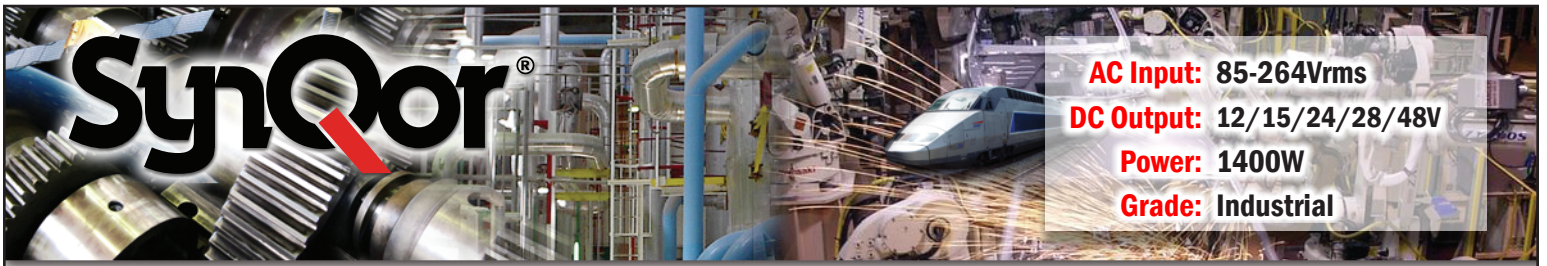

AC Leakage Current from Input to Earth	AC Line Connection	Normal Condition	Open Neutral Fault
ACuQor Typical at 110% nominal input voltage 60 Hz	240 V L-N, 1 phase	400 μ A	800 μ A
	208 V L-L, 120 V L-N, 1 of 3 phases	200 μ A	400 μ A
	240 V L-N-L, 120 V L-N, split phase	200 μ A	400 μ A

Table 1: Leakage Currents

Standard Testing Certifications

SAFETY AGENCY CERTIFICATIONS

CAN/CSA-C22.2 No. 62368-1

UL 62368-1

EN 62368-1

CE Marked

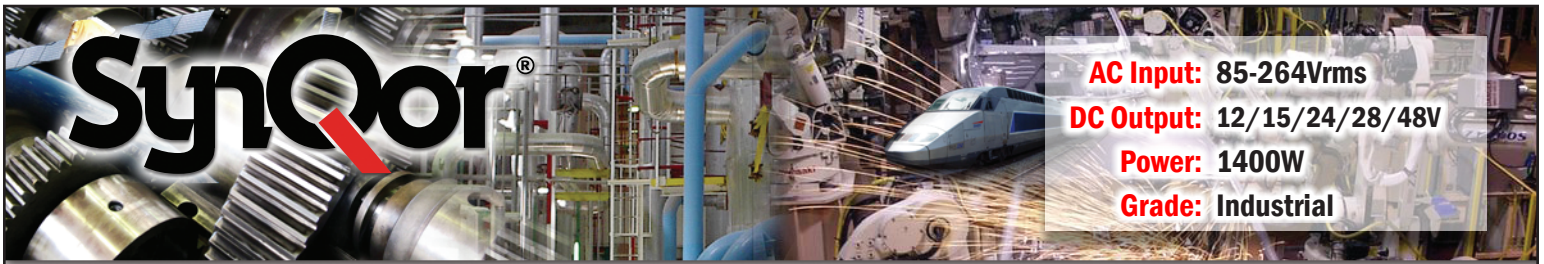

PARALLEL OPERATION

General

Up to 3 units may be parallel connected for higher power if the parallel option is specified (see Part Numbering System on last page). All units must be of the same output voltage and power rating. Only 24 V, 28 V, and 48 V output models are supported. With the parallel option, the Vout droop shown in Figures 6, 8, and 10 is precisely controlled and slightly modified (~1%) beyond rated power. As a result, full rated power and current is guaranteed from a bank of multiple units wired in parallel. Parallel option units may still be used stand-alone.

Specifications of Parallel Units

As a rule, units connected in parallel behave the same as single units. Any specification will remain unchanged that is expressed in units of voltage, time, frequency, or efficiency. Specifications expressed in terms of power, current, or capacitance, should be scaled by the number of units wired in parallel.

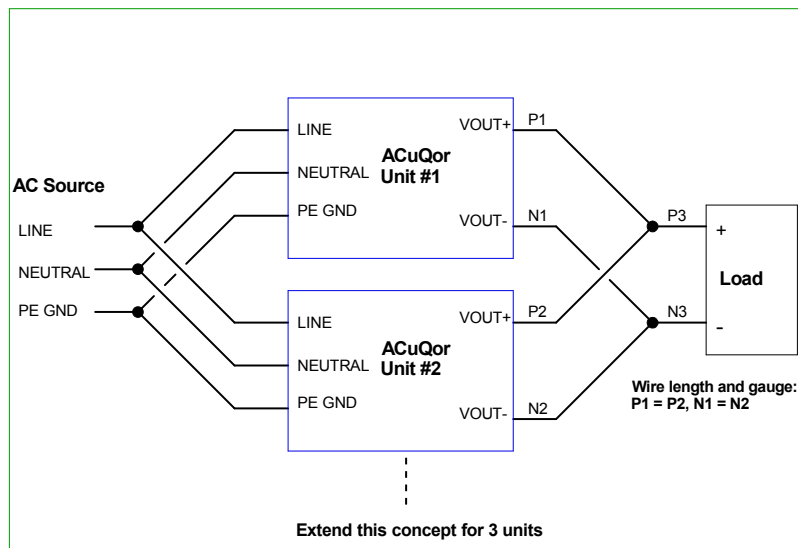

Figure P1: Parallel Power Connections

Interconnection of Parallel Units

The AC inputs and DC outputs must be parallel connected as shown in Figure P1. The length and gauge of the wires for each ACuQor output should be matched to within 10% to match electrical resistance and thereby achieve optimum sharing.

Signal connections will vary by application. The simplest case is shown in Figure P2 where the ACuQors are wired to self-enable on power-up and other signals are not in use. Beyond this simple case, there are isolated and non-isolated connection schemes.

Figure P3 shows an example of a non-isolated signal connection strategy. Because the Vout- is used as both the power and signal return, consideration must be given to preventing large load currents from flowing through the signal return. A current magnitude of greater than 5 A can damage the signal connector or cable. This can happen if the Vout- power connection of one unit becomes disconnected while loaded.

Figure P4 shows an example of an isolated signal connection strategy. The opto-isolation prevents load currents from flowing through the signal cable under any condition.

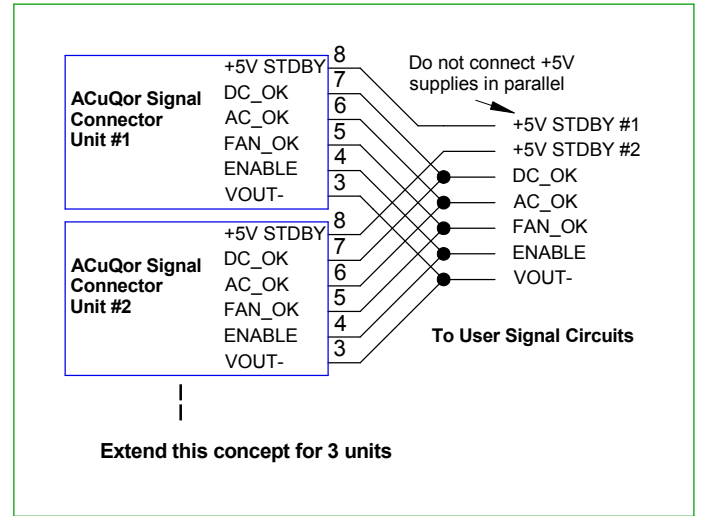
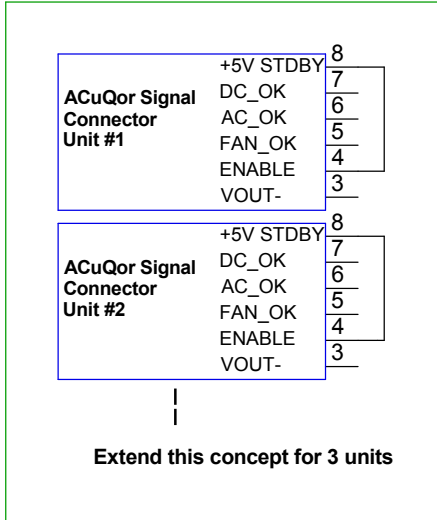
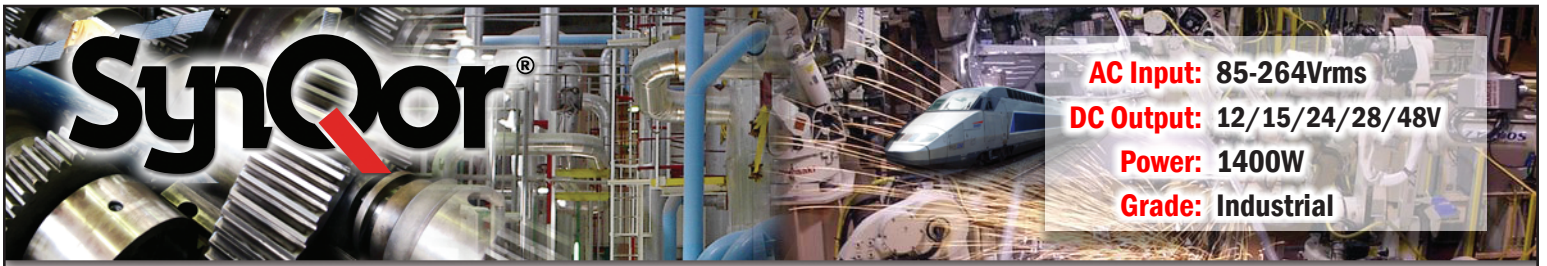

Figure P2: Simplest Signal Connections

Figure P3: Non-Isolated Signal Connections

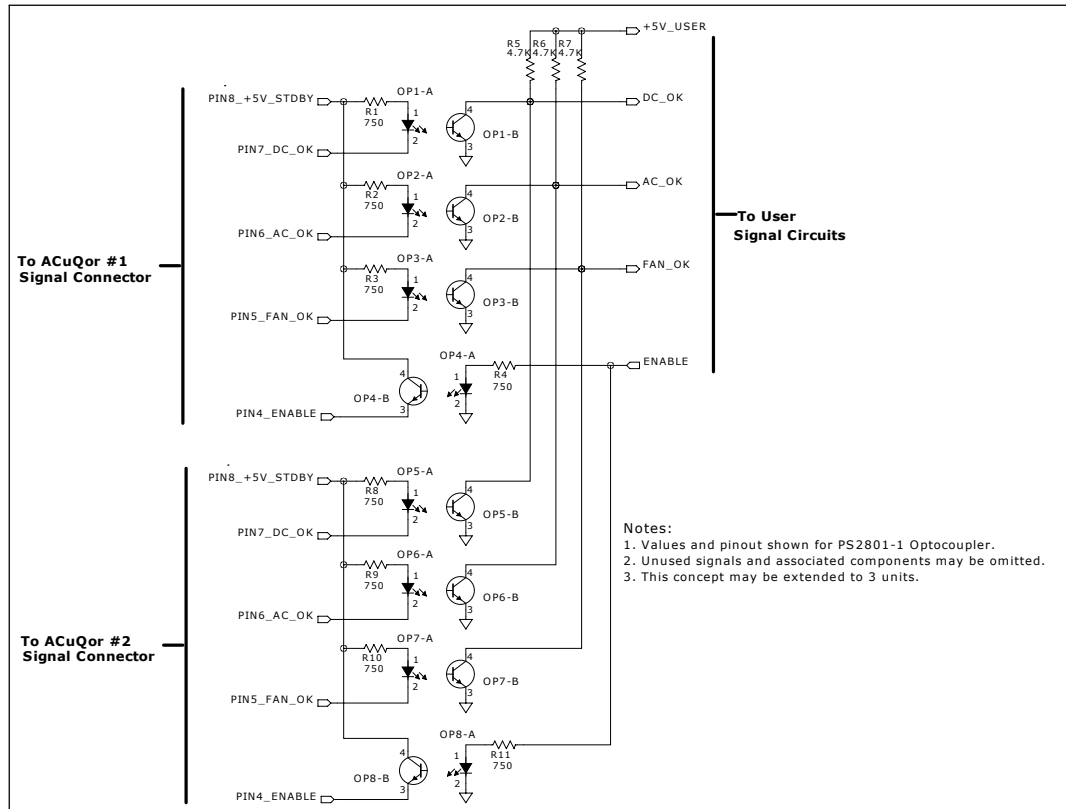
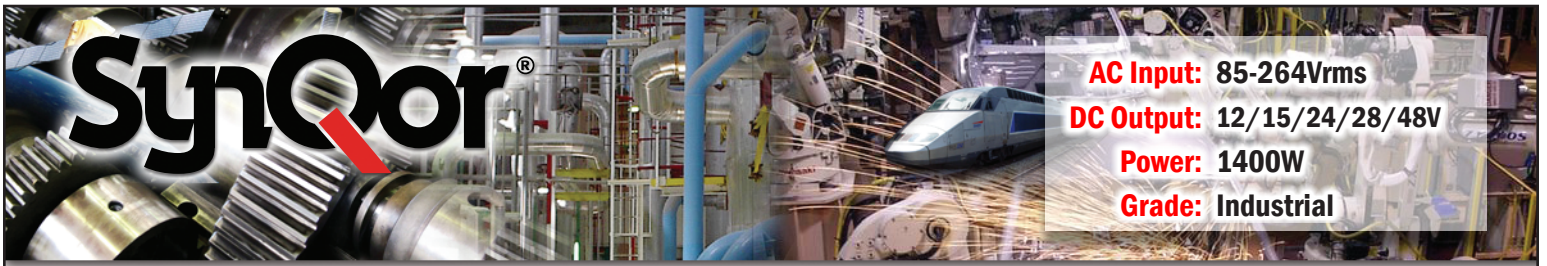
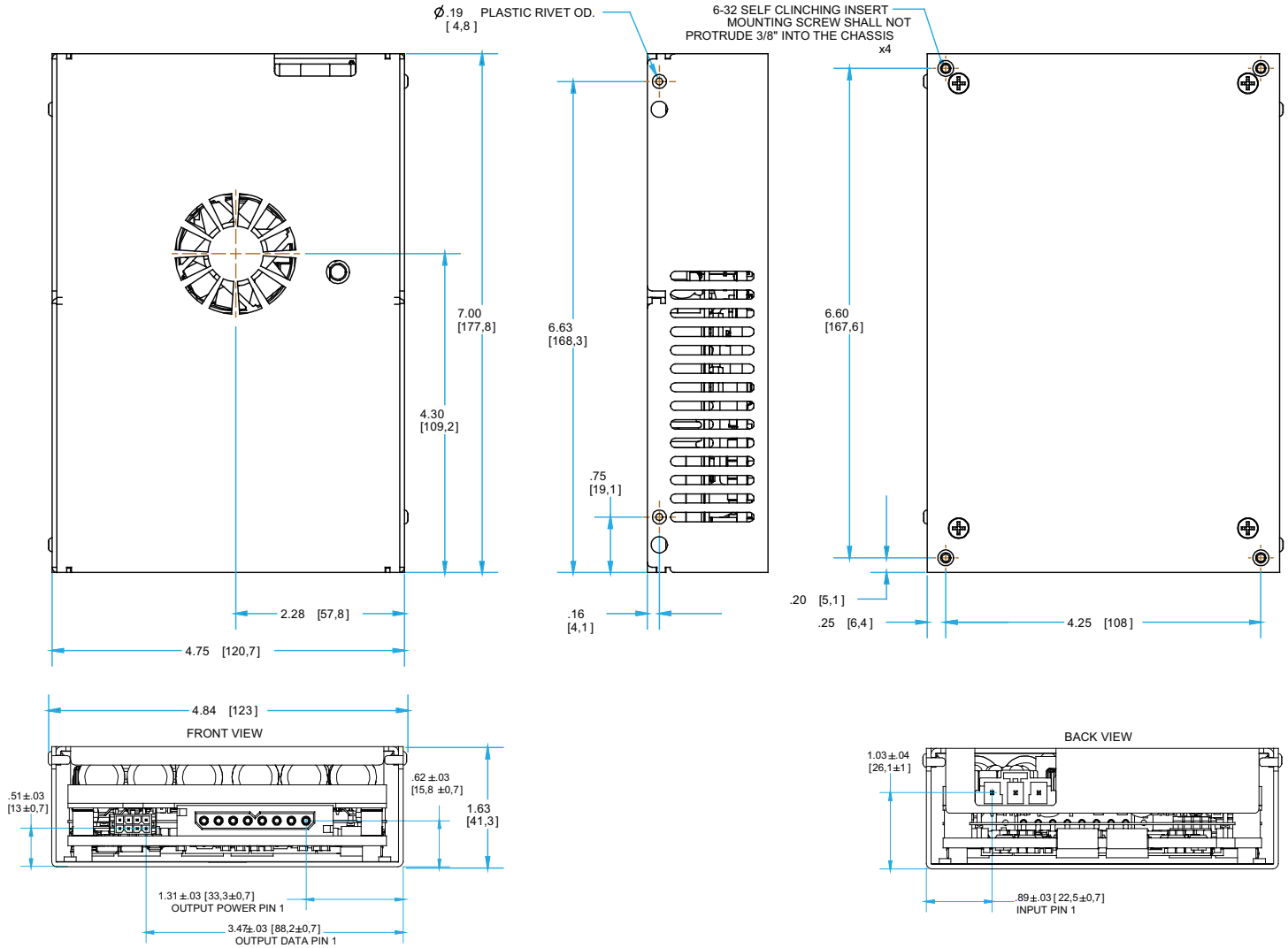

Figure P4: Isolated Signal Connections



MECHANICAL DRAWINGS



NOTES

1. Recommended screw tightening torque of 6in.. lbs.
2. Undimensioned components are shown for visual reference only
3. All dimensions in inches [mm]
 Tolerances: x.xx in ± 0.02
 x.xxx in ± 0.010

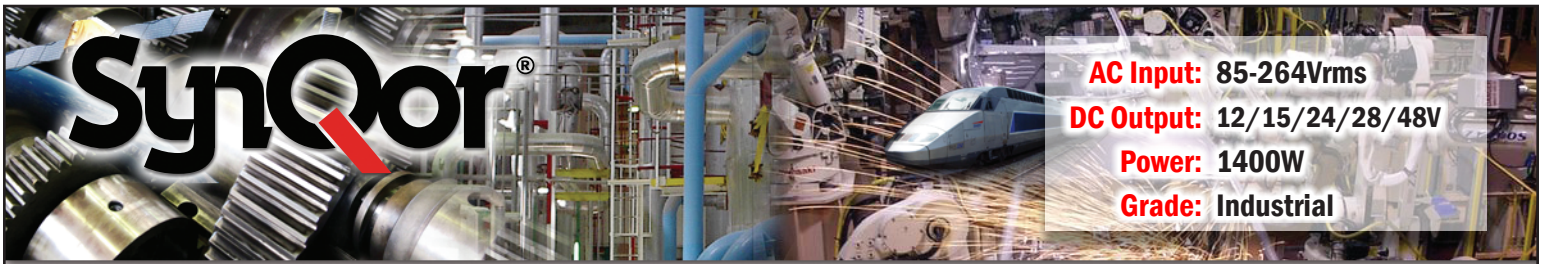

INSTALLATION INSTRUCTIONS

GENERAL INFORMATION: ACuQor AC/DC power supplies are intended for use as components in medical and industrial equipment. ACuQor units must be properly installed within end use equipment before they can be safely applied as described in this document. The suitability of the ACuQor/equipment combination must be verified through end product investigation.

MOUNTING: Refer to the Mechanical Drawings section. ACuQor units are provided with threaded stainless-steel stand-offs or inserts for mounting. This mounting hardware is internally connected to the input connector protective-earth terminal for functional-earth EMC control. Any orientation (vertical, horizontal, etc.) may be used. Adequate air space should be provided over the fan intake (top) and exhaust (sides) to allow for exchange of cooling air. ACuQor is designed for a pollution degree 2 environment. A minimum of 5 mm electrical clearance should be allowed from the connector ends of encased models.

INPUT: Refer to the Connector Details section for input connector wiring. ACuQor products require a single phase AC power source of 100-240V 50/60Hz nominal. Refer to nameplate label for input current ratings. A protective-earth connection is also required. Minimum wire size of 14 AWG (2.5mm²) is recommended. Both sides of the AC line are internally fused (see table for specifications). These fuses are not user replaceable.

OUTPUT: Refer to the Connector Details section for the output connector wiring and signal I/O functionality. Refer to nameplate label for output current ratings. Main DC output (Vout+, Vout-) pins should use 12 AWG (4.0mm²) wire size. Individual main output pins should not be loaded to more than 30 A. For currents greater than 30 A, multiple main output pins/wires must be used in parallel. All signal I/O pins are referenced to Vout-.

EMC: ACuQor products have been tested to the EMC specifications listed in the section of the datasheet titled Electrical Characteristics, on page two. However, end use equipment must be tested to verify EMC compliance.

HIPOT TESTING: ACuQor products are rated for Hipot testing levels of 1768 Vac input to protective-earth, 500 Vac output to protective-earth, and 3000 Vac input to output. When performing the 3000 Vac input to output test, the test voltage must be balanced evenly 1500 Vac input and output to protective-earth. Two oppositely phased test voltage sources or a single test voltage source with external balancing impedances (capacitors) may be used to prevent overstressing input or output to protective-earth insulation per IEC/EN 62368-1.

CONDUCTIVE COOLING: The AQ1400 model requires supplemental conductive cooling through its case to maintain the rated output power. The case should be mounted to a system chassis or heat sink with a thermally conductive interface material and kept at 50°C maximum to maintain full power rating of the product. For detailed applications assistance, consult Applications Engineering through the sales channel.

MODEL	Input Fuses (in Both AC Lines)	Fuses Total
AQ0800	Safety agency recognized 20A 250V fast blow	2
AQ1100	Safety agency recognized 20A 250V fast blow	2
AQ1400	Safety agency recognized 20A 250V fast blow	2

Table 2: AC line fuses for specific ACuQor Medical Models

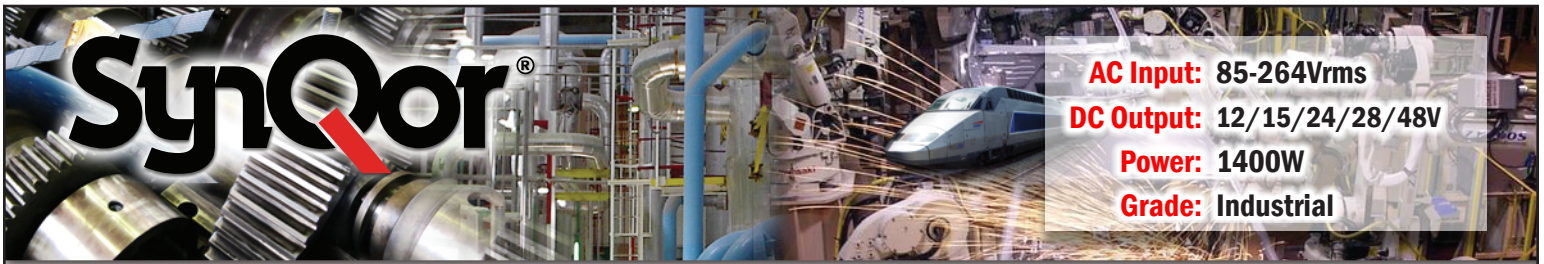

PART NUMBERING SYSTEM

The part numbering system for SynQor’s ACuQor AC/DC power supplies follows the format shown in the table below. Not all combinations make valid part numbers, please contact SynQor for availability.

Family	Output Power	Grade	Range	Output Voltage	Package Type	Thermal Design	Options
AQ: ACuQor series of AC-DC semi-regulated output power supplies	0800: 800W 1100: 1100W 1400: 1400W	I: (Industrial)	U: Universal (85-264 VRMS)	12: 12V 15: 15V 24: 24V 28: 28V 48: 48V	G: 1 unit (5"x7")	C: Encased	IND: Industrial Grade INP: Parallel *

* Parallel output capable with up to 3 units. 12 V and 15 V outputs excluded.

Example: AQ1400IU24GCIND

ACCESSORIES

SynQor offers a series of assemblies that can be ordered according to the table below. Mechanical drawings for these accessories are available for download in pdf format from the SynQor website.

Part Number	Description
AQ-CBL-INPUT1CG	Input mating cable with pre-stripped wire ends (36" long)
AQ-CBL-OUT1CDG	Output mating cables (Signal and Power) with pre-stripped wire ends (18" long)

APPLICATION NOTES

A variety of application notes and technical white papers can be downloaded in pdf format from the SynQor website.

- [Online Application Notes](#)
- [Online Library of Technical White Papers](#)
- [SynQor website.](#)

Contact SynQor for further information and to order:

Phone: 978-849-0600 Fax: 978-849-0602
 E-mail: power@synqor.com Web: www.synqor.com
 Address: 155 Swanson Road, Boxborough, MA 01719 USA

Warranty

SynQor offers a two (2) year limited warranty. Complete warranty information is listed on our website or is available upon request from SynQor.

PATENTS

SynQor holds numerous U.S. patents, one or more of which apply to most of its power conversion products. Any that apply to the product(s) listed in this document are identified by markings on the product(s) or on internal components of the product(s) in accordance with U.S. patent laws. SynQor’s patents include the following:

- 7,765,687 7,787,261
- 8,149,597 8,644,027